

ITEM NO.	QTY.	PART NO.	DESCRIPTION	ITEM NO.	QTY.	PART NO.	DESCRIPTION
1	1	P731 (1001HV)	BASE, SPEEDSTER	59	4	H770	BOLT, 1/4-20 x 1/2" LG. SERRATED FLANGE
2	3	H296	COOLING FAN WIRE GUARD	60	2	H204	BOLT, 1/4-20 x 1-3/4" LG. HEX HEAD
3	12	H297	SCREW, SLEF-TAPPING, #8 x 1/2" LG.	61	1	H896	LATCH BRACKET
4	1	C317	FAN, COOLING (115V)	62	2	H922	THUMB SCREW, BLACK PLASTIC
5	1	H253	PLATE, DUAL MANIFOLD, 9" x 13"	63	2	H602	"L" BRACKET
6	16	H210	WASHER, FLAT, 1/4"	64	8	H877	#10 LOCK WASHER
7	10	H342	BOLT, HEX HD., 1/4-20 x 1" LG.	65	8	H230	SCREW, #10-32 x 1/2" LG. PHIL. PAN HD.
8	12	H216	LOCKNUT, 1/4-20 HEX, NYLON INSERT	66	3	B103	90 DEG 1/4" M x FM
9	2	P735	SINGLE MANIFOLD	67	6	H876	1/2" FLAT WASHER
10	2	G004	GASKET, VACUUM MOTOR	68	2	B111	ADAPTER, 1/4" M x 1/4" FM
<b>11</b>	<b>2</b>	<b>C310</b>	<b>MOTOR, HI-PERF. 2 STAGE 115V</b>	69	1	B107	NIPPLE, 1/4" HEX
12	4	H217	HOSE CLAMP	70	1	AH105	HOSE, 3/8" SURGE x 15-3/4" LG.
13	1	G059	EXHAUST BOOT, PLASTISOL	71	2	H413	WASHER, NYLON
14	6	H768	BOLT, 1/4-20 x 3/4" LG. SERRATED FLANGE	72	1	B106	NIPPLE, 1/4" CLOSE
15	6	H500	2-STAGE VACUUM SUPPORT	73	1	B102	QUICK DISCONNECT, 1/4" FEMALE
16	6	H201	BOLT, 1/4-20 x 1/2" LG. HEX HEAD	74	1	B186	ELBOW, 90 DEG, 3/8" M x FM
17	1	PH627 (Speedster1)	VACUUM HOSE, 1-1/2" x 22" LG.	75	2	H299	WASHER, .688 x 1.50 x .075
18	2	H300	HOSE CUFF, 1-1/2"	76	1	B216	NIPPLE, 3/8" CLOSE
19	1	G059 (MODIFIED)	EXHAUST BOOT, PLASTISOL	77	1	B210	BUSHING, 1/2 m x 3/8 fm
20	1	PH627 (Speedster2)	VACUUM HOSE, 1-1/2" x 22" LG.	78	1	B119A	FILTER STRAINER, 1/2"
<b>21</b>	<b>1</b>	<b>C305</b>	<b>PUMP, 100 psi</b>	79	2	H203	HEX BOLT, 1/4-20 x 1-1/4" LG.
22	12	H289	WASHER, FLAT, #10	80	2	H213	1/4" LOCK WASHER
23	2	H273	KEP-NUT, #10-32, ZINC	81	4	H211	WASHER, 1/4" ID x 1" OD
24	2	H222	#10-32 x 1-1/4" LG. PHIL. PAN HD. SCREW	82	4	G052	BUNA WASHER, 1-1/8" OD x 3/16" ID
25	1	B105	REDUCER, 3/8" M x 1/4" FM	83	2	H215	1/4-20 HEX NUT
26	1	B136	90 DEG 1/4" M x M	84	1	P733	VACUUM TANK, SPEEDSTER
27	1	AH156	HOSE, 3/8" SURGE x 4" LG.	85	1	H225	DRAIN VALVE, 1-1/2"
28	1	B172	90 DEG 1/2" B x 3/8" MP	86	1	H226	DRAIN SPOUT, 45 DEG.
29	2	H347	HOSE CLAMP	87	3	H229	INLET FITTING, PVC, GRAY, 1-1/2"
30	1	PH615 (1001HV)	1/2" KURITEK x 21" LG.	88	2	H244	ADAPTER, PVC, 1-1/2"
31	1	B160	FITTING, 1/2 BARB x 3/8 FM SWIVEL	89	2	PH633-11	PIPE, PVC, 1-1/2" x 11" LG.
32	1	H439	HEATER ASSEMBLY, DUAL CAPSULE	90	2	P755	ELBOW FOR FLOAT ASSEMBLY
<b>33</b>	<b>2</b>	<b>E519</b>	<b>HEATING ROD, 1000W, 115V</b>	91	2	H235	FLOAT CAGE
34	2	E573	THERMOSTAT, 210 DEG AUTO	92	1	G060	VACUUM LID GASKET
35	8	H447	NUT, KEP, M3	93	1	G056	LID, VACUUM TANK
36	2	E574	THERMOSTAT, 375 DEG MANUAL	94	6	H304	SCREW, #8-32 x 5/8" LG. PHIL. OVAL
37	1	B142	COUPLING, 1/4"	95	1	G010	BAG, FILTER
38	1	B108	CHECK VALVE, 1/4"	96	1	A925	INLET ELBOW ASSEMBLY
39	1	B113	1/4" TEE (ALL FEMALE)	97	1	G001	GASKET, INLET, 1-1/2"
40	1	AH106 (1001HV)	HOSE, 3/8" SURGE x 20" LG.	98	1	H348	SWITCH PLATE, 4-HOLE
41	1	B124	VALVE, 175 psi RELIEF	99	2	H612	#8 FLAT WASHER
42	1	B109	FITTING, 1/4" BARB x 1/4" MPT	100	2	H246	SCREW, #8-32 x 3/8" LG. SOCKET HD. CAP
43	2	B116	FERREL (FOR 1/4" HOSE)	101	1	E512	LIGHT, GREEN CIRCUIT INDICATOR
44	1	PH634 (1001HV)	HOSE (1/4" KURITEK x 25" LG.)	102	3	E515	SWITCH, 2 POSITION ROCKER
45	1	B110	FITTING, 1/4 BARB x 1/4 FM SWIVEL	103	1	E516	3 POSITION ROCKER SWITCH
46	1	H371	AXLE, 1/2" x 18-1/2" LG.	104	2	H375	HANGER, WIRE FORMED
47	2	H251	WHEEL, 12"				
48	4	H254	WASHER, AXLE, 5/8" ID				
49	2	H219	1/2" AXLE CAP				
50	2	H666	CASTER, 5" DIA.				
51	2	H220	CORD STRAIN RELIEF FITTING				
52	2	H221	1/2" STEEL LOCK NUT				
53	2	E550	30" POWER CORD PIGTAIL				
54	2	G131	CONNECTOR, CORD				
55	2	E530	POWER CORD, 50'				
56	1	P732 (1001HV)	SOLUTION TANK, SPEEDSTER				
57	1	G018A	COVER, SOLUTION TANK (FB & SPEEDSTER)				
58	1	H378	BRACKET, FRONT HINGE				

ADDITIONAL COMPONENTS NOT SHOWN:

WIRING HARNESS COMPONENTS

- E513 - WIRE TIES, SMALL
- L401A - BOX, MACHINE
- L401B - BOX, TOP TRAY
- L478 - BOX, BOTTOM SUPPORT
- L807 - LABEL SET, SPEEDSTER 1001
- L829 - LABEL SET, SAFETY
- L854 - LABEL, HIGH VELOCITY

**PROPRIETARY AND CONFIDENTIAL**  
 THE INFORMATION CONTAINED IN THIS DRAWING IS THE SOLE PROPERTY OF MYTEE PRODUCTS, INC. ANY REPRODUCTION IN PART OR AS A WHOLE WITHOUT THE WRITTEN PERMISSION OF MYTEE PRODUCTS, INC. IS PROHIBITED.

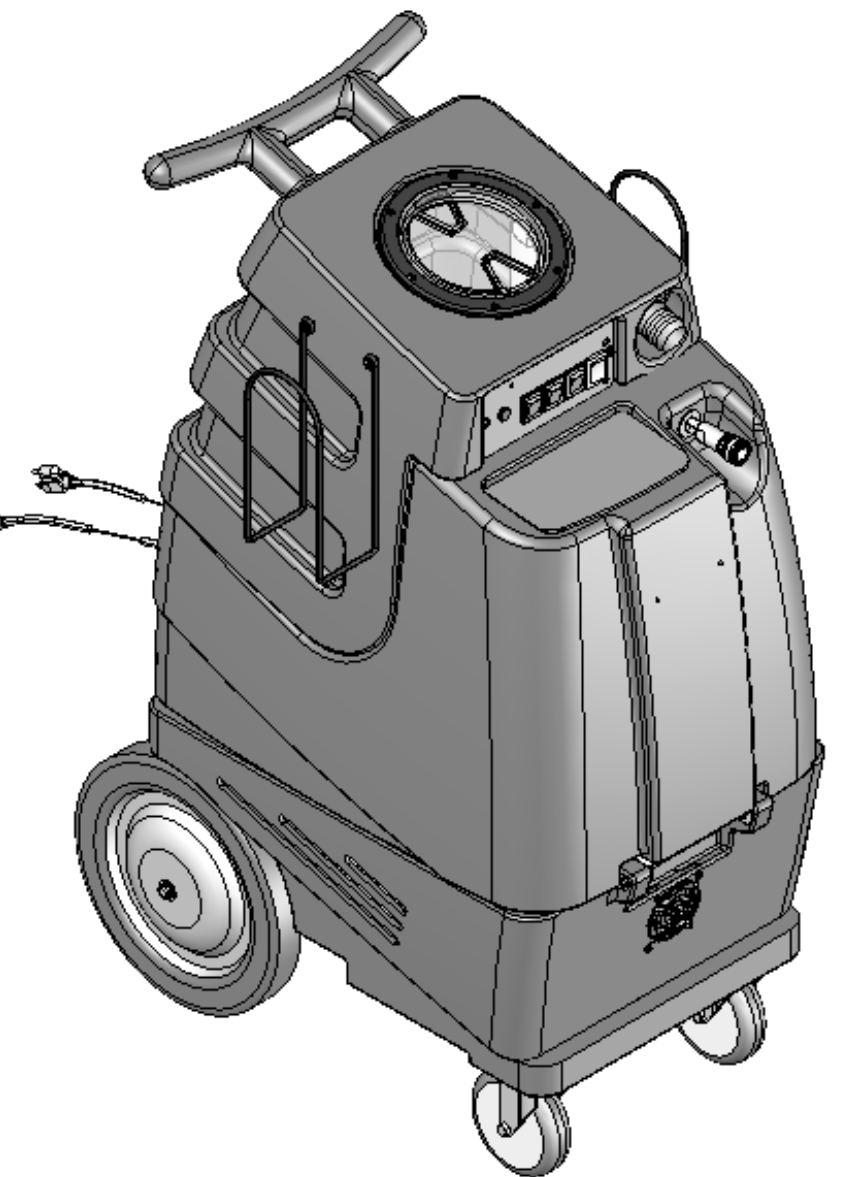

REVISIONS				
ZONE	REV.	DESCRIPTION	DATE	APPROVED
	B	REPLACED H212 WITH H876	4/21/04	
	C	NEW HEATER; ADDED WIRE HANGERS	8/19/04	

UNLESS OTHERWISE SPECIFIED:		DATE	NAME	<b>MYTEE PRODUCTS, INC.</b> TITLE: <b>SPEEDSTER, 1001HV ASSEMBLY</b>	
DIMENSIONS ARE IN INCHES		DRAWN	11/25/03		J. BEVIER
TOLERANCES:		CHECKED			
FRACTIONAL: ± .015		ENG APPR.			
ANGULAR: MACH ±		MFG APPR.			
TWO PLACE DECIMAL ± .010		COMMENTS:			
THREE PLACE DECIMAL ± .005		SEE B.O.M.			
MATERIAL	FINISH	USED ON:		SCALE: 1:8	
SEE B.O.M.		APPLICATION		DO NOT SCALE DRAWING	
				SHEET 1 OF 4	

SIZE **C** DWG. NO. **00003** REV **C**

REVISIONS				
ZONE	REV.	DESCRIPTION	DATE	APPROVED
	B	REPLACED H212 WITH H876	4/21/04	
	C	NEW HEATER; ADDED WIRE HANGERS	8/19/04	

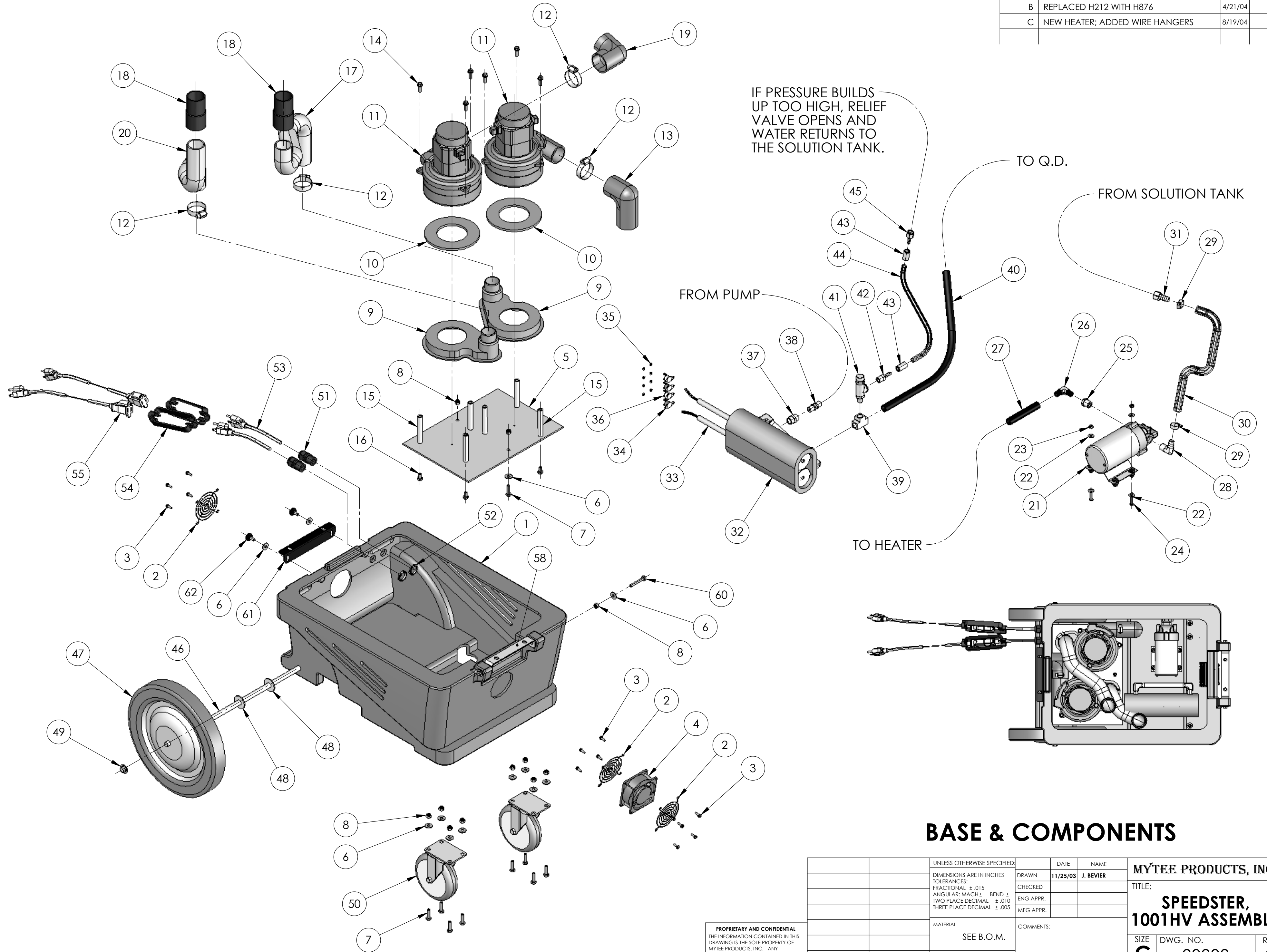

IF PRESSURE BUILDS UP TOO HIGH, RELIEF VALVE OPENS AND WATER RETURNS TO THE SOLUTION TANK.

TO Q.D.

FROM SOLUTION TANK

FROM PUMP

TO HEATER

## BASE & COMPONENTS

**PROPRIETARY AND CONFIDENTIAL**  
 THE INFORMATION CONTAINED IN THIS DRAWING IS THE SOLE PROPERTY OF MYTEE PRODUCTS, INC. ANY REPRODUCTION IN PART OR AS A WHOLE WITHOUT THE WRITTEN PERMISSION OF MYTEE PRODUCTS, INC. IS PROHIBITED.

UNLESS OTHERWISE SPECIFIED:		DATE	NAME	MYTEE PRODUCTS, INC.
DIMENSIONS ARE IN INCHES TOLERANCES: FRACTIONAL: ± .015 ANGULAR: MACH ± TWO PLACE DECIMAL ± .010 THREE PLACE DECIMAL ± .005		11/25/03	J. BEVIER	
MATERIAL		COMMENTS:		TITLE:
SEE B.O.M.				<b>SPEEDSTER, 1001HV ASSEMBLY</b>
FINISH		USED ON:		SCALE: 1:6
NEXT ASSY	USED ON			DO NOT SCALE DRAWING
APPLICATION				SHEET 2 OF 4

SIZE	DWG. NO.	REV
<b>C</b>	<b>00003</b>	<b>C</b>



REVISIONS				
ZONE	REV.	DESCRIPTION	DATE	APPROVED
	B	REPLACED H212 WITH H876	4/21/04	
	C	NEW HEATER; ADDED WIRE HANGERS	8/19/04	

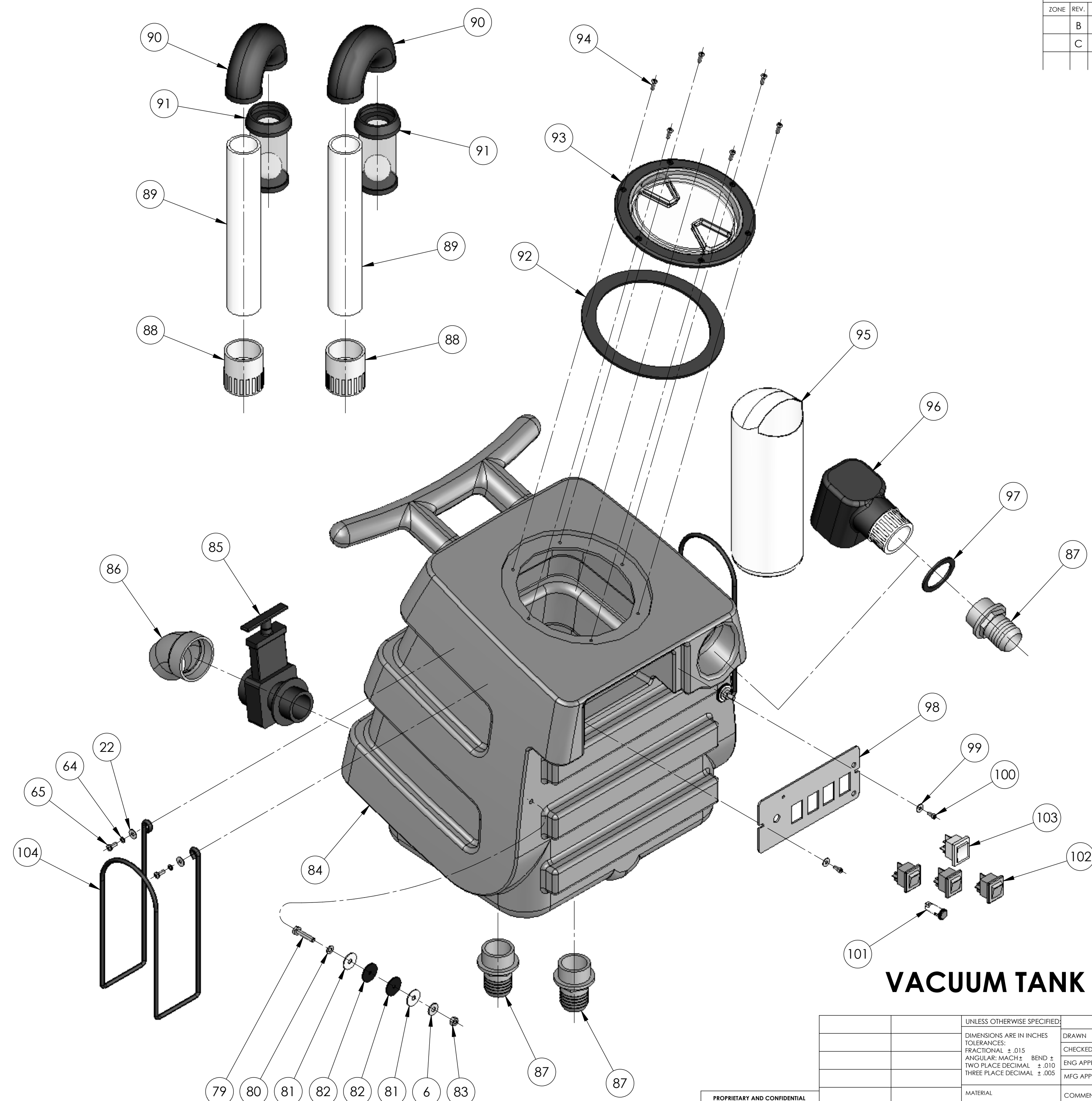

THESE FASTENERS HOLD THE SOLUTION TANK AND VACUUM TANK TOGETHER.

# VACUUM TANK & COMPONENTS

**PROPRIETARY AND CONFIDENTIAL**  
 THE INFORMATION CONTAINED IN THIS DRAWING IS THE SOLE PROPERTY OF MYTEE PRODUCTS, INC. ANY REPRODUCTION IN PART OR AS A WHOLE WITHOUT THE WRITTEN PERMISSION OF MYTEE PRODUCTS, INC. IS PROHIBITED.

UNLESS OTHERWISE SPECIFIED:		DATE	NAME	<b>MYTEE PRODUCTS, INC.</b> TITLE: <b>SPEEDSTER, 1001HV ASSEMBLY</b>
DIMENSIONS ARE IN INCHES		DRAWN	11/25/03 J. BEVIER	
TOLERANCES:		CHECKED		
FRACTIONAL: ± .015		ENG APPR.		
ANGULAR: MACH ±		MFG APPR.		COMMENTS:  
BEND ±				
TWO PLACE DECIMAL ± .010				
THREE PLACE DECIMAL ± .005				SIZE <b>C</b> DWG. NO. <b>00003</b> REV <b>C</b>
MATERIAL	SEE B.O.M.	SCALE: 1:4		
FINISH		DO NOT SCALE DRAWING		
NEXT ASSY	USED ON	SHEET 4 OF 4		
APPLICATION				