

ITEM NO.	QTY.	PART NO.	DESCRIPTION	ITEM NO.	QTY.	PART NO.	DESCRIPTION
1	1	P731	BASE, SPEEDSTER	59	1	B186	ELBOW, 90 DEG, 3/8" M x FM
2	2	H296	COOLING FAN WIRE GUARD	60	2	H299	WASHER, .688 x 1.50 x .075
3	8	H206	SCREW, HEX HD., SELF-TAPPING, #10-32 x 1/2" LG.	61	1	B216	NIPPLE, 3/8" CLOSE
4	1	H253	PLATE, DUAL MANIFOLD, 9" x 13"	62	1	B210	BUSHING, 1/2 m x 3/8 fm
5	16	H210	WASHER, FLAT, 1/4"	63	1	B119A	FILTER STRAINER, 1/2"
6	10	H342	BOLT, HEX HD., 1/4-20 x 1" LG.	64	2	H203	HEX BOLT, 1/4-20 x 1-1/4" LG.
7	12	H216	LOCKNUT, 1/4-20 HEX, NYLON INSERT	65	2	H213	1/4" LOCK WASHER
8	2	P735	SINGLE MANIFOLD	66	4	H211	WASHER, 1/4" ID x 1" OD
9	2	G004	GASKET, VACUUM MOTOR	67	4	G052	BUNA WASHER, 1-1/8" OD x 3/16" ID
				68	2	H215	1/4-20 HEX NUT
<b>10</b>	<b>2</b>	<b>C310</b>	<b>MOTOR, HI-PERF. 2 STAGE 115V</b>	69	1	P733	VACUUM TANK, SPEEDSTER
11	4	H217	HOSE CLAMP	70	1	H225	DRAIN VALVE, 1-1/2"
12	1	G059	EXHAUST BOOT, PLASTISOL	71	1	H226	DRAIN SPOUT, 45 DEG.
13	6	H768	BOLT, 1/4-20 x 3/4" LG. SERRATED FLANGE	72	3	H229	INLET FITTING, PVC, GRAY, 1-1/2"
14	6	H500	2-STAGE VACUUM SUPPORT	73	2	H244	ADAPTER, PVC, 1-1/2"
15	6	H201	BOLT, 1/4-20 x 1/2" LG. HEX HEAD	74	2	PH633-11	PIPE, PVC, 1-1/2" x 11" LG.
16	1	PH627 (Speedster1)	VACUUM HOSE, 1-1/2" x 22" LG.	75	2	P755	ELBOW FOR FLOAT ASSEMBLY
17	2	H300	HOSE CUFF, 1-1/2"	76	2	H235	FLOAT CAGE
18	1	G059 (MODIFIED)	EXHAUST BOOT, PLASTISOL	77	1	G060	VACUUM LID GASKET
19	1	PH627 (Speedster2)	VACUUM HOSE, 1-1/2" x 22" LG.	78	1	G056	LID, VACUUM TANK
				79	6	H304	SCREW, #8-32 x 5/8" LG. PHIL. OVAL
<b>20</b>	<b>1</b>	<b>C305</b>	<b>PUMP, 100 psi</b>	80	1	G010	BAG, FILTER
21	12	H289	WASHER, FLAT, #10	81	1	A925	INLET ELBOW ASSEMBLY
22	2	H273	KEP-NUT, #10-32, ZINC	82	1	G001	GASKET, INLET, 1-1/2"
23	2	H222	#10-32 x 1-1/4" LG. PHIL. PAN HD. SCREW	83	1	H338	SWITCH PLATE, 3-HOLE
24	1	B105	REDUCER, 3/8" M x 1/4" FM	84	2	H612	#8 FLAT WASHER
25	1	B136	90 DEG 1/4" M x M	85	2	H246	SCREW, #8-32 x 3/8" LG. SOCKET HD. CAP
26	1	AH106	HOSE, 3/8" SURGE x 20" LG.	86	3	E515	SWITCH, 2 POSITION ROCKER
27	1	B172	90 DEG 1/2" B x 3/8" MP	87	2	H375	HANGER, WIRE FORMED
28	2	H347	HOSE CLAMP				
29	1	PH615-21	HOSE, 1/2" KURITEK x 21" LG.				
30	1	B160	FITTING, 1/2 BARB x 3/8 FM SWIVEL				
31	1	H371	AXLE, 1/2" x 18-1/2" LG.				
32	2	H251	WHEEL, 12"				
33	4	H254	WASHER, AXLE, 5/8" ID				
34	2	H219	1/2" AXLE CAP				
35	2	H666	CASTER, 5" DIA.				
36	1	H220	CORD STRAIN RELIEF FITTING				
37	1	H221	1/2" STEEL LOCK NUT				
38	1	E550	30" POWER CORD PIGTAIL				
39	1	G131	CONNECTOR, CORD				
40	1	E530	POWER CORD, 50'				
41	1	P732	SOLUTION TANK, SPEEDSTER				
42	1	G018A	COVER, SOLUTION TANK (FB & SPEEDSTER)				
43	1	H378	BRACKET, FRONT HINGE				
44	4	H770	BOLT, 1/4-20 x 1/2" LG. SERRATED FLANGE				
45	2	H204	BOLT, 1/4-20 x 1-3/4" LG. HEX HEAD				
46	1	H896	LATCH BRACKET				
47	2	H922	THUMB SCREW, BLACK PLASTIC				
48	2	H602	"L" BRACKET				
49	8	H877	#10 LOCK WASHER				
50	8	H230	SCREW, #10-32 x 1/2" LG. PHIL. PAN HD.				
51	2	B103	90 DEG 1/4" M x FM				
52	4	H876	1/2" FLAT WASHER				
53	1	B107	NIPPLE, 1/4" HEX				
54	1	AH105	HOSE, 3/8" SURGE x 15-3/4" LG.				
55	2	H413	WASHER, NYLON				
56	1	B106	NIPPLE, 1/4" CLOSE				
57	1	B111	ADAPTER, 1/4" M x 1/4" FM				
58	1	B102	QUICK DISCONNECT, 1/4" FEMALE				

ADDITIONAL COMPONENTS NOT SHOWN:

WIRING HARNESS COMPONENTS

- E513 - WIRE TIES, SMALL
- L401A - BOX, MACHINE
- L401B - BOX, TOP TRAY
- L478 - BOX, BOTTOM SUPPORT
- L806 - LABEL SET, SPEEDSTER 1000
- L854 - LABEL, HIGH VELOCITY

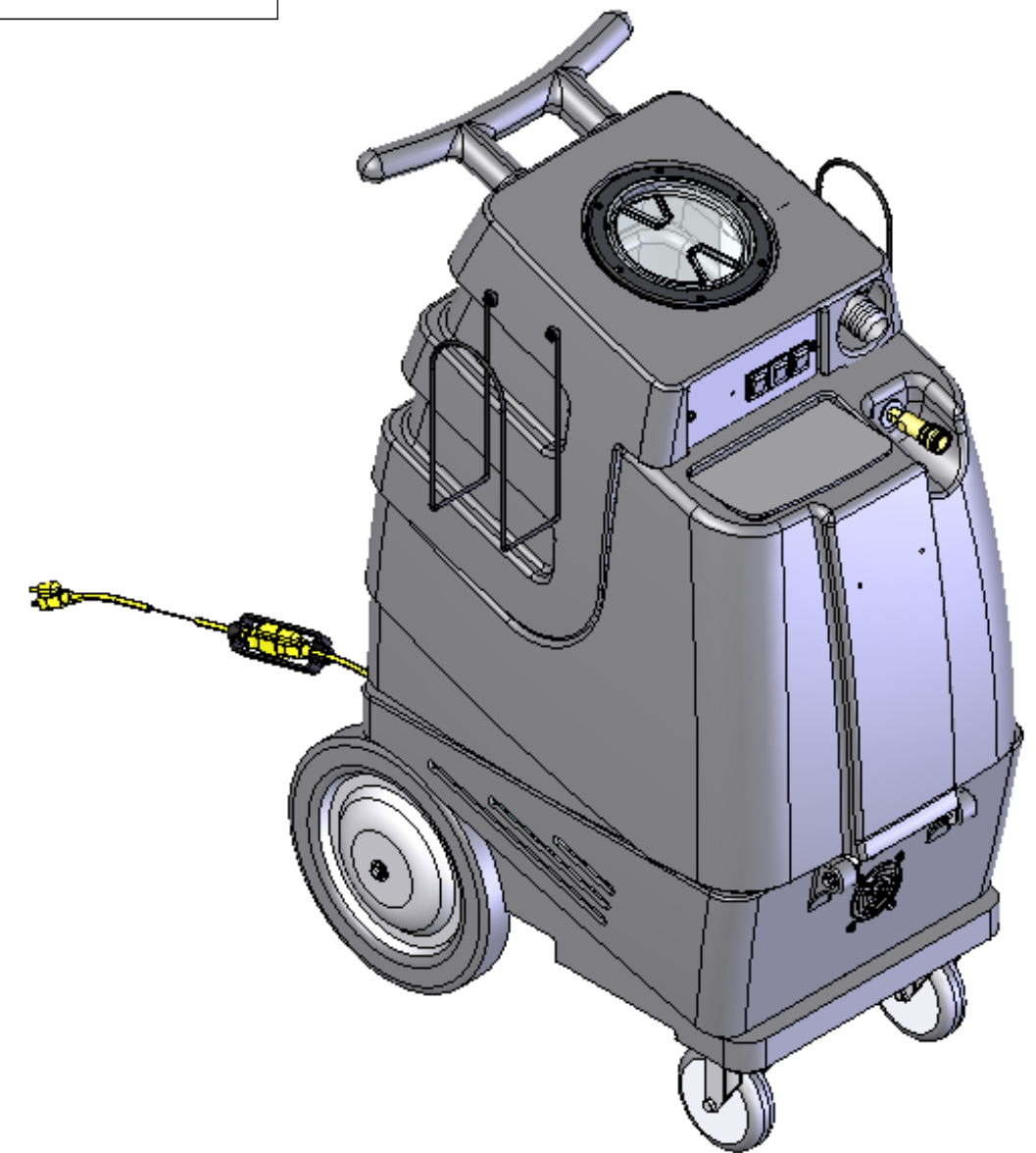

REVISIONS				
ZONE	REV.	DESCRIPTION	DATE	APPROVED
	B	REPLACED H212 WITH H876	4/21/04	
	C	ADDED THUMB SCREWS / WIRE HANGERS	7/30/04	

**PROPRIETARY AND CONFIDENTIAL**  
 THE INFORMATION CONTAINED IN THIS DRAWING IS THE SOLE PROPERTY OF MYTEE PRODUCTS, INC. ANY REPRODUCTION IN PART OR AS A WHOLE WITHOUT THE WRITTEN PERMISSION OF MYTEE PRODUCTS, INC. IS PROHIBITED.

UNLESS OTHERWISE SPECIFIED:		DATE	NAME	<b>MYTEE PRODUCTS, INC.</b> TITLE: <b>SPEEDSTER, 1000HV ASSEMBLY</b> SIZE <b>C</b> DWG. NO. <b>00002</b> REV <b>C</b> SCALE: 1:8 DO NOT SCALE DRAWING SHEET 1 OF 4
DIMENSIONS ARE IN INCHES		DRAWN	11/25/03 J. Bevier	
TOLERANCES:		CHECKED		
FRACTIONAL: ± .015 ANGULAR: MACH ± BEND ± TWO PLACE DECIMAL ± .010 THREE PLACE DECIMAL ± .005		ENG APPR.		
MATERIAL		COMMENTS:		
SEE B.O.M.				
FINISH				
NEXT ASSY	USED ON			
APPLICATION		USED ON:		

REVISIONS				
ZONE	REV.	DESCRIPTION	DATE	APPROVED
	B	REPLACED H212 WITH H876	4/21/04	
	C	ADDED THUMB SCREWS / WIRE HANGERS	7/30/04	

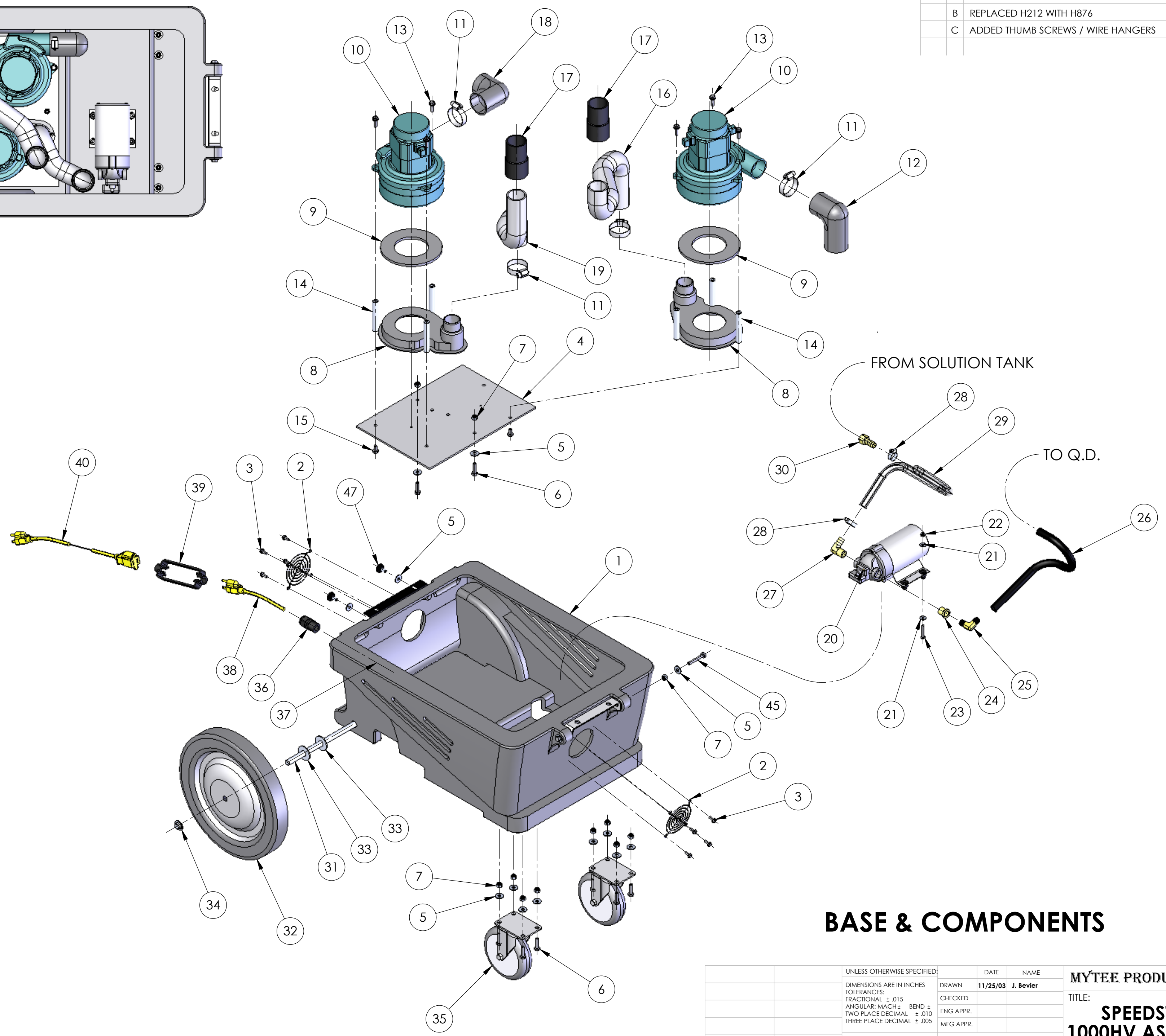
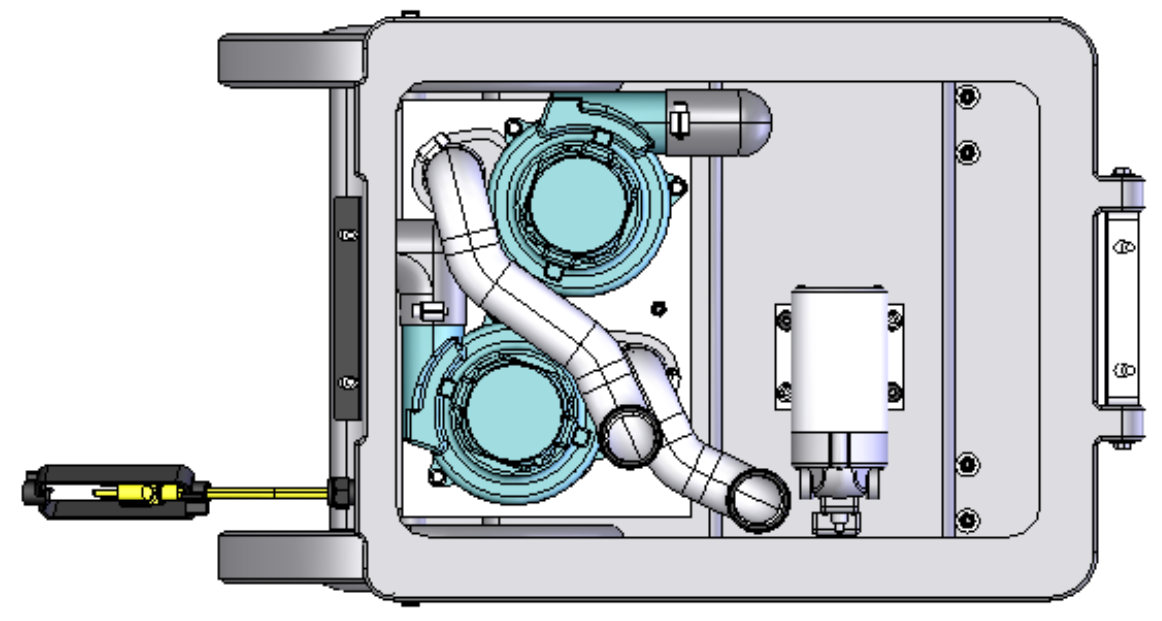

FROM SOLUTION TANK

TO Q.D.

# BASE & COMPONENTS

**PROPRIETARY AND CONFIDENTIAL**  
 THE INFORMATION CONTAINED IN THIS DRAWING IS THE SOLE PROPERTY OF MYTEE PRODUCTS, INC. ANY REPRODUCTION IN PART OR AS A WHOLE WITHOUT THE WRITTEN PERMISSION OF MYTEE PRODUCTS, INC. IS PROHIBITED.

UNLESS OTHERWISE SPECIFIED:		DATE	NAME	<b>MYTEE PRODUCTS, INC.</b> TITLE: <b>SPEEDSTER, 1000HV ASSEMBLY</b> SIZE DWG. NO. REV <b>C 00002 C</b> SCALE: 1:6 DO NOT SCALE DRAWING SHEET 2 OF 4
DIMENSIONS ARE IN INCHES		DRAWN	11/25/03 J. Bevier	
TOLERANCES:		CHECKED		
FRACTIONAL: ± .015		ENG APPR.		
ANGULAR: MACH ±		MFG APPR.		
TWO PLACE DECIMAL ± .010		COMMENTS:		
THREE PLACE DECIMAL ± .005				
MATERIAL		SEE B.O.M.		
FINISH				
NEXT ASSY	USED ON			
APPLICATION				

REVISIONS				
ZONE	REV.	DESCRIPTION	DATE	APPROVED
	B	REPLACED H212 WITH H876	4/21/04	
	C	ADDED THUMB SCREWS / WIRE HANGERS	7/30/04	

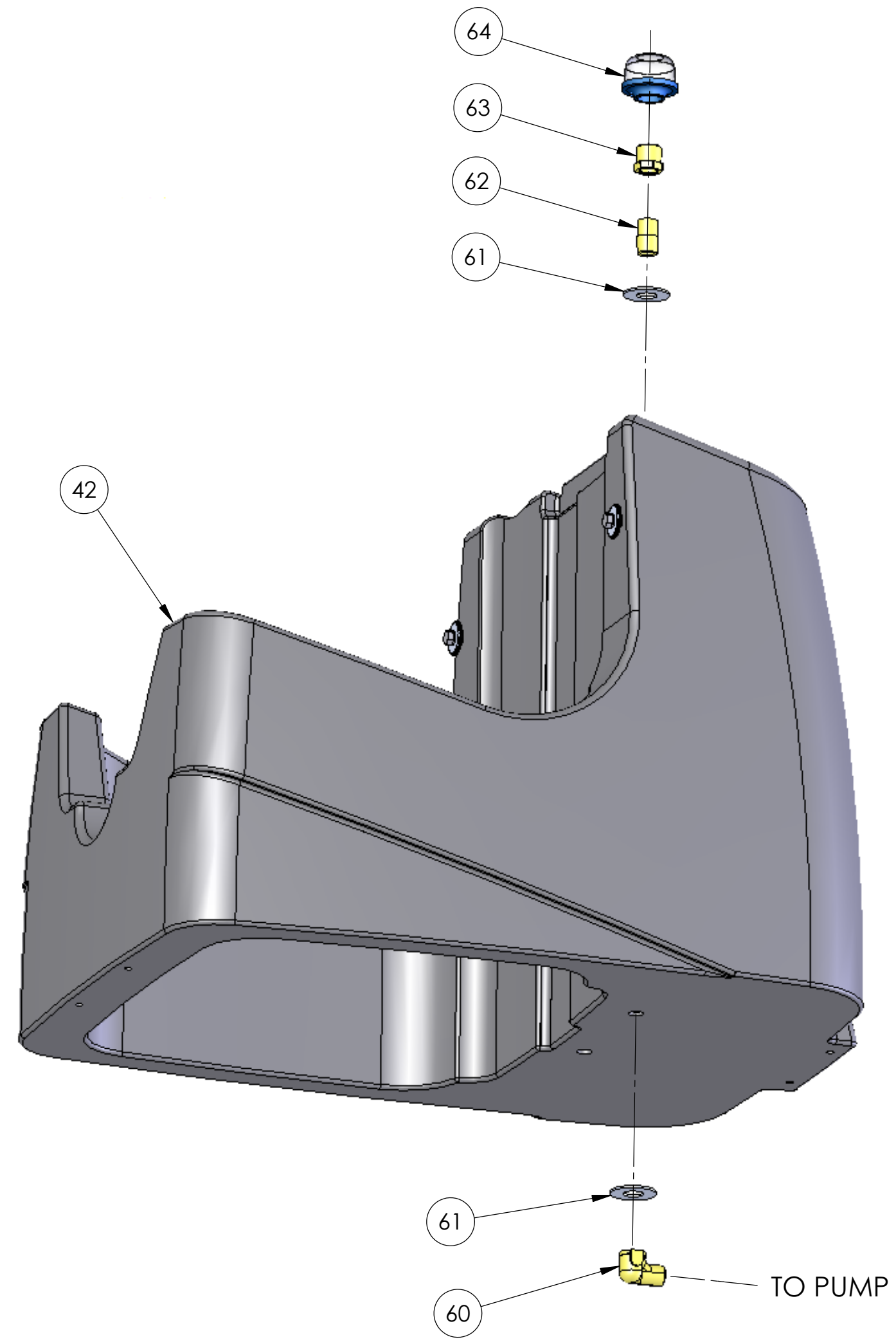
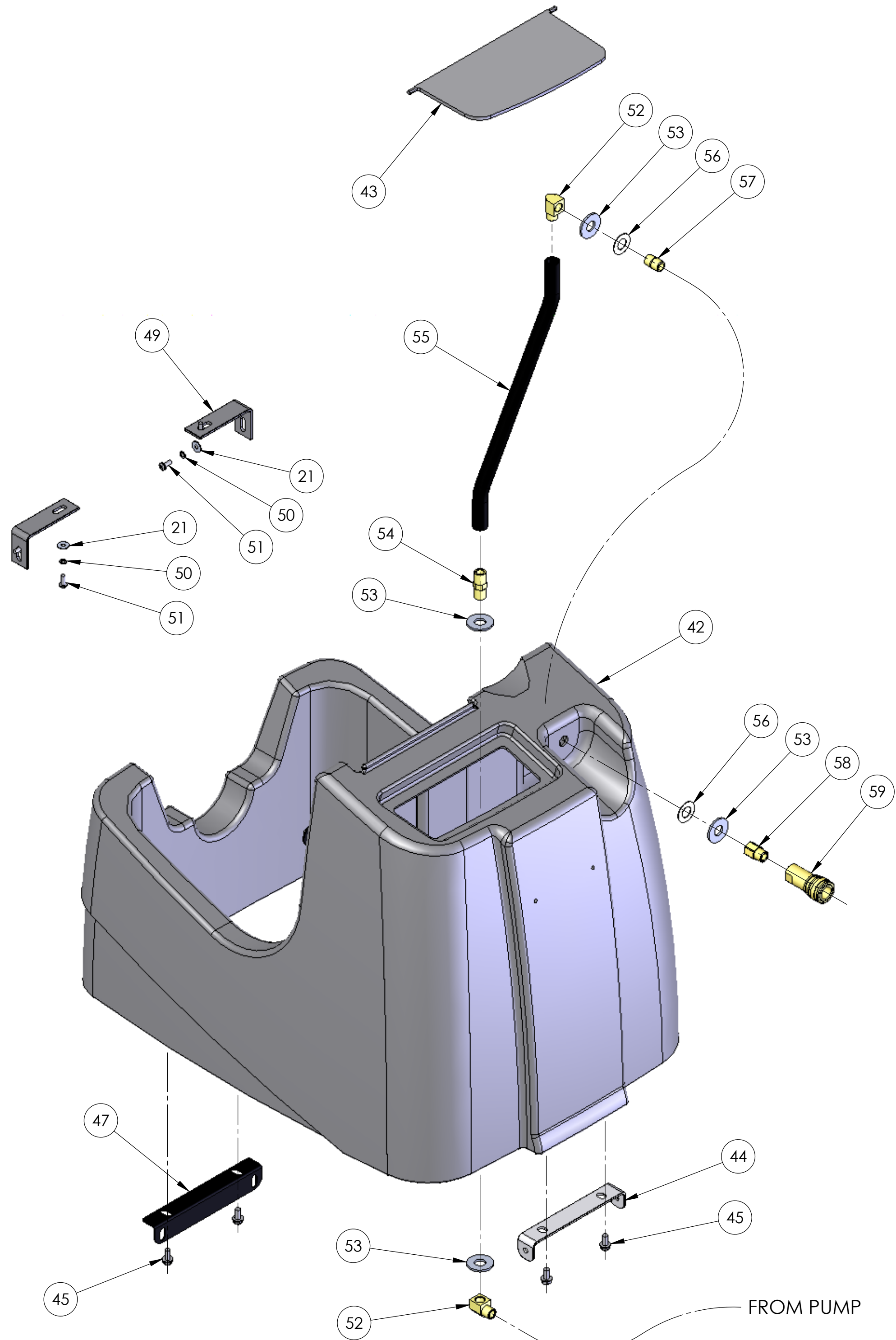

# SOLUTION TANK & COMPONENTS

**PROPRIETARY AND CONFIDENTIAL**  
 THE INFORMATION CONTAINED IN THIS DRAWING IS THE SOLE PROPERTY OF MYTEE PRODUCTS, INC. ANY REPRODUCTION IN PART OR AS A WHOLE WITHOUT THE WRITTEN PERMISSION OF MYTEE PRODUCTS, INC. IS PROHIBITED.

UNLESS OTHERWISE SPECIFIED:		DATE	NAME	MYTEE PRODUCTS, INC.
DIMENSIONS ARE IN INCHES TOLERANCES: FRACTIONAL: ± .015 ANGULAR: MACH ± BEND ± TWO PLACE DECIMAL ± .010 THREE PLACE DECIMAL ± .005		11/25/03	J. Bevier	
MATERIAL		COMMENTS:		TITLE:
SEE B.O.M.				<b>SPEEDSTER, 1000HV ASSEMBLY</b>
NEXT ASSY	USED ON	FINISH	USED ON:	SIZE DWG. NO. REV
				<b>C 00002 C</b>
APPLICATION			SCALE: 1:4	DO NOT SCALE DRAWING SHEET 3 OF 4

REVISIONS				
ZONE	REV.	DESCRIPTION	DATE	APPROVED
	B	REPLACED H212 WITH H876	4/21/04	
	C	ADDED THUMB SCREWS / WIRE HANGERS	7/30/04	

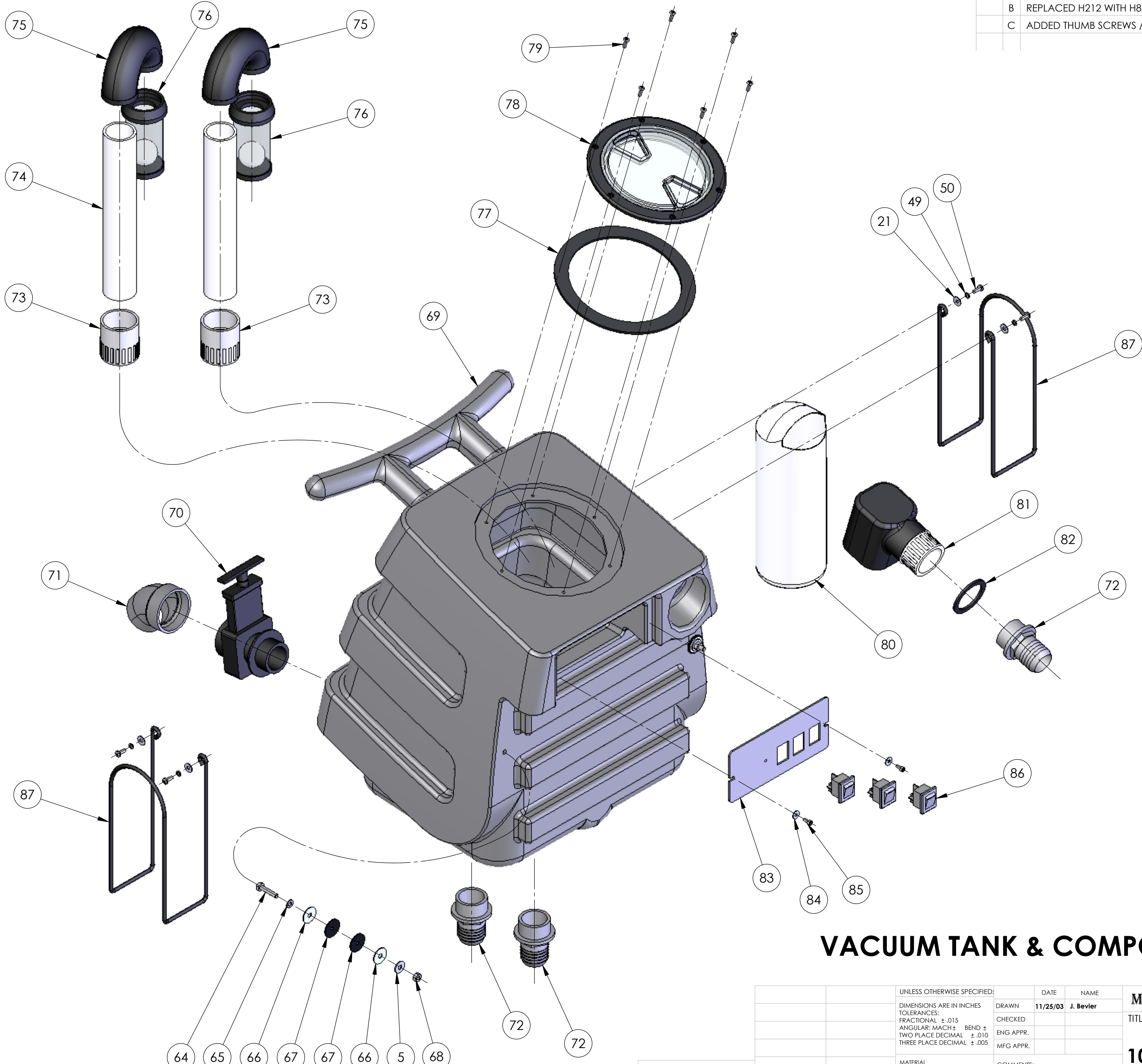

THESE FASTENERS HOLD THE SOLUTION TANK AND VACUUM TANK TOGETHER.

PROPRIETARY AND CONFIDENTIAL  
 THE INFORMATION CONTAINED IN THIS DRAWING IS THE SOLE PROPERTY OF MYTEE PRODUCTS, INC. ANY REPRODUCTION IN PART OR AS A WHOLE WITHOUT THE WRITTEN PERMISSION OF MYTEE PRODUCTS, INC. IS PROHIBITED.

# VACUUM TANK & COMPONENTS

UNLESS OTHERWISE SPECIFIED:		DATE	NAME	MYTEE PRODUCTS, INC.
DIMENSIONS ARE IN INCHES TOLERANCES: FRACTIONAL: ± .015 ANGULAR: MACH ±     BEND ± TWO PLACE DECIMAL ± .010 THREE PLACE DECIMAL ± .005		11/25/03	J. Bevier	
MATERIAL	SEE B.O.M.	COMMENTS:		SIZE <b>C</b>
FINISH				DWG. NO. <b>00002</b>
NEXT ASSY	USED ON	USED ON:		REV <b>C</b>
APPLICATION				SCALE: 1:4
				DO NOT SCALE DRAWING
				SHEET 4 OF 4